

TECHNICAL BULLETIN

**INSTRUCTIONS TO CONVERT
T130E1 TRACK
TO
T150F TRACK
USING
KIT 57K4269(2530-01-502-3401)
ON
M113A3 FOV CARRIERS,
M113A2 FOV CARRIERS,
M548A1/A3 CARRIERS
AND
OSV/MBT VEHICLES**

DISTRIBUTION STATEMENT A: Approved for public release; distribution is unlimited

WARNING SUMMARY

WARNING SUMMARY

This is a summary of critical WARNINGS in this bulletin. They are repeated here to let you know how important they are. Study these WARNINGS carefully; they can save your life and the lives of personnel you work with.

WARNING

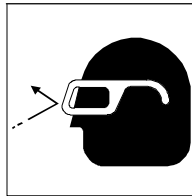

Always wear eye protection when using a hammer. Eye injury may result if metal chips contact eyes.

WARNING

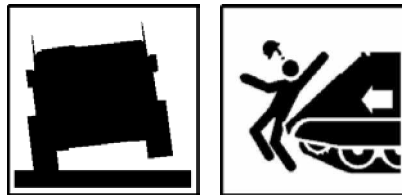

Improper number of track shoes may prevent track from being adjusted correctly, creating a safety hazard. Personnel may be killed and equipment damaged. For carriers with new track, ensure there are 63 track shoes on the left side of carrier and 64 track shoes on the right side of carrier for the M113A2 FOV, M113A3 FOV and OSV. For the M548A1/A3, 66 track shoes are required for both sides.

WARNING

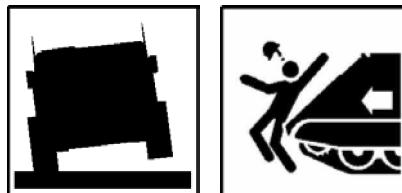

Do not use a crowbar on the track shoe pins to get leverage. Any scratches may cause the pin to break and cause the track assembly to fall off the vehicle while operating. This may kill soldiers and damage equipment. Use crowbar as shown in the following steps to get leverage to install the end connectors.

WARNING



Not getting the bolt tight enough may result in death to personnel and damage to equipment if the end connectors fall off during movement of the vehicle.

For first aid information, see FM 4-25.11.

INSERT LATEST UPDATED PAGES/WORK PACKAGES. DESTROY SUPERSEDED DATA.

LIST OF EFFECTIVE PAGES/WORK PACKAGES

Dates of issue for original and updated pages/work packages are:

Original 0 (28 February 2007)

TOTAL NUMBER OF PAGES FOR FRONT AND REAR MATTER IS 18 AND TOTAL NUMBER OF WORK PACKAGES IS 3 CONSISTING OF THE FOLLOWING:

	Page/WP No.	*Change No.	Page/WP No.	Change No.	Page/WP No.	*Change No.
Cover		0				
a/b		0				
A/B blank		0				
i-ii		0				
WP 0001 00		0				
WP 0002 00		0				
WP 0003 00		0				
Index-1/Index-2 blank		0				

*Zero in this column indicates an original page

TECHNICAL BULLETIN
No. 9-2350-369-20-1

HEADQUARTERS
DEPARTMENT OF THE ARMY
WASHINGTON, D.C., 28 February 2007

Technical Bulletin
MODIFICATION TO CONVERT M113A3 FOV CARRIERS, M113A2 FOV
CARRIERS,
M548A1/A3 CARRIERS AND OSV/MBT VEHICLES
T130E1 TRACK TO T150F TRACK

REPORTING ERRORS AND RECOMMENDING IMPROVEMENTS

You can help improve this publication. If you find any mistakes or if you know of a way to improve the procedures, please let us know. Submit your DA Form 2028 (Recommended Changes to Publications and Blank Forms), through the Internet, on the Army Electronic Product Support (AEPS) website. The Internet address is <http://aeeps.ria.army.mil>. If you need a password, scroll down and click on "ACCESS REQUEST FORM." The DA 2028 is located in the ONLINE FORMS PROCESSING section of the AEPS. Fill out the form and click on SUBMIT. Using this form on the AEPS will enable us to respond quicker to your comments and better manage the DA Form 2028 program. You may also mail, fax, or E-mail your letter or DA Form 2028 direct to: AMSTA-LC-LPIT Tech Pubs, TACOM-RI, 1 Rock Island Arsenal, Rock Island, IL 61299-7630. The e-mail address is ROCK-TACOM-TECH-PUBS@conus.army.mil. The fax number is DSN 793-0726 or Commercial (309) 782-0726.

DISTRIBUTION STATEMENT A: Approved for public release; distribution is unlimited.

TABLE OF CONTENTS

	WP Sequence No.
Warning Summary	
Safety Summary	
Introduction	0001 00
Modification Procedures/Sequencing	0002 00
References	0003 00
Index	Index-1

SAFETY SUMMARY

GENERAL SAFETY INSTRUCTIONS.

This publication describes physical and chemical processes, which may cause injury or death to personnel or damage to equipment if not properly followed. This safety summary includes general safety precautions and instructions that must be understood and applied during operation and maintenance to ensure personnel safety and protection of equipment. Prior to performing any task, the WARNINGS, CAUTIONS and NOTES included in that task shall be reviewed and understood.

WARNINGS, CAUTIONS, AND NOTES

WARNINGS and CAUTIONS are used in this publication to highlight operating or maintenance procedures, practices, conditions or statements, which are considered essential to protection of personnel (WARNING) or equipment (CAUTION). WARNINGS and CAUTIONS immediately precede the step or procedure to which they apply. WARNINGS and CAUTIONS consist of four parts: heading (WARNING, CAUTION, and ICON), a statement of the hazard, minimum precautions, and possible result if disregarded. NOTES are used in this publication to highlight operating or maintenance procedures, practices, conditions or statements which are not essential to protection of personnel or equipment. NOTES may precede or follow the step or procedure, depending upon the information to be highlighted. The headings used and their definitions are as follows.

WARNING

Highlights an essential operating or maintenance procedure, practice, condition, statement, etc, which, if not strictly observed, could result in injury to, long term health hazards for, or death of, personnel.

CAUTION

Highlights an essential operating or maintenance procedure, practice, condition, statement, etc, which, if not strictly observed, could result in damage to or destruction of equipment, or loss of mission effectiveness.

NOTE

Highlights an essential operating or maintenance procedure, condition, or statement.

INTRODUCTION**0001 00****Purpose.**

The purpose of this technical bulletin (TB) is to replace the T130E1 track assembly and install the T150F track assembly. Kit 57K4269 provides all the parts to modify the sprocket carrier 10942567 and provides the crew tools for installing/removing T150 track. The T150 track assembly is procured separately through your unit funds. The kit applies to the vehicles identified in Table 1. The kit is designed for either field or depot installation.

General.

- a. Priority. This bulletin is classified ROUTINE.
- b. End Item(s) or System(s) to be modified. Modification will be in accordance with Table 1.

Table 1. VEHICLES TO BE MODIFIED

NOMENCLATURE	NSN	PART NO.	CAGEC
Carrier, Personnel, M113A3	2350-01-219-7577	8750170	19207
Carrier, 120mm Mortar, M1064A3	2350-01-369-6082	8750287	19207
Carrier, SICPS, M1068A3	2350-01-369-6086	8750288	19207
Carrier, Command Post, M577A3	2350-01-369-6085	8750286	19207
Carrier, Smoke Generator, M1059A3	2350-01-369-6083	8750290	19207
Carrier, Full Tracked, M58	2350-01-418-6654	12408400	19207
Carrier, Personnel, M113A2	2350-01-068-4077	8750024	19207
Carrier, Command Post, M577A2	2350-01-068-4089	8750025	19207
Carrier, Smoke Generator, M1059	2350-01-203-0188	8750136	19207
Carrier, SICPS, M1068	2350-01-354-5657	8750249	19207
Carrier, 120mm Mortar, M1064	2350-01-338-3116	8750248	19207
Carrier, Improved TOW, M901A1	2350-01-103-5641	8750063	19207
Carrier, FISTV, M981	2350-01-085-3792	8750031	19207
Carrier, Cargo, M548A1	2350-01-096-9356	8750029	19207
Carrier, Cargo, M548A3	2350-01-369-6081	8750289	19207
Opposing Forces Surrogate (OSV) M113A3/BMP-2	6920-01-420-4716	137490	57039

- c. Module(s), (Components, Assemblies, Subassemblies, Boards and Cards) to be Modified. The following items, whether installed in PLL/ASL or depot stock shall be modified. Not applicable.

INTRODUCTION (continued)

0001 00

- d. Parts to be Modified. The following items, whether installed in PLL/ASL or depot stock shall be modified. Stocked parts shall be modified prior to issue and shall be marked so that it can be easily distributed that modification has been accomplished. Not applicable
- e. Application.
 - (1) Time Compliance Schedule: NA
 - (2) Level of Maintenance: The lowest level of maintenance authorized to perform modifications described by this TB is Unit Maintenance.
 - (3) Applied By: Unit/direct/general support/depot or contractor civilian personnel consisting of tracked vehicle mechanics (63Y-63T MOS) and/or heavy mobile equipment mechanics.
 - (4) Time Required: Time for TB application to one end item is estimated to be 4 man-hours.
 - (5) Modifications to be Applied to or Concurrently with the Application of this kit. None.
 - (6) Additional Information. Kit application will be concurrent with other depot overhaul/conversion programs, as applicable. Mechanic and two helpers are required to apply this kit.

f. Technical Publications Affected/Changed:

DMWR 9-2350-277	DMWR 9-2350-261	DMWR 9-2350-247	DMWR 9-2530-200/2
TM 9-2350-277-10	TM 9-2350-261-10	TM 9-2350-247-10	TM 9-2350-366-10-1
TM 9-2350-277-20	TM 9-2350-261-20	TM 9-2350-247-20	TM 9-2350-366-20-1
TM 9-2350-277-24P	TM 9-2350-261-24P	TM 9-2350-247-24P	TM 9-2350-366-24P-1
			TM 9-2530-200-24

- g. Modification Kits/Parts, and Their Disposition.
 - (1) Kit(s)/Part(s) needed to apply this modification.

NOMENCLATURE	CAGEC	PART NO. NSN
Modification Kit, T150F Suspension Less Track (Does not include T150F Track Shoes, need to be ordered separately)	19207	57K4269 2530-01-502-3401

- (2) Contents of TB Kit. See Table 2.

Table 2. MODIFICATION KIT 57K4269

NSN	NOMENCLATURE	CAGEC	PART NO.	QUANTITY
3020-01-496-4445	Sprocket	19207	12474840	4
5340-01-496-7433	Adapter Ring	19207	12474843	4
2520-00-679-9657	Cushion	19207	8763180	4
5340-01-496-5173	Bracket	19207	12474841	2
5310-01-497-2285	Washer	19207	12474863	4
5310-00-809-5998	Washer	96906	MS27183-18	8
5305-00-071-2067	Screw	80204	B1821BH050C125N	4
5305-00-071-2069	Screw	80204	B1821BH050C150N	4
5306-01-132-3363	Bolt	96906	MS35764-1545	20
5305-01-496-6745	Bolt	96906	MS35764-1445	40
5220-01-504-2610	Tool, Alignment Trk Pin	19207	12474881	2
5220-01-496-3692	Track Gauge	19207	12474849	1
5120-01-496-3689	Remover	19207	12474798	1
5130-00-227-6681	Wrench Socket	55719	IM-362	1
5120-00-221-7959	Wrench Handle	19207	12474720	1
5120-00-473-6320	Handle Extension	55719	36A	1

INTRODUCTION (continued)**0001 00**

Not included in kit or 57K4269 but will be needed if being applied to a M981 or M901A1 for mounting the track stowage brackets.

NSN	NOMENCLATURE	CAGEC	PART NO.	QUANTITY
5305-00-071-2077	Screw	80204	B1821BH050C350N	4

(3) Bulk and Expendable Material. Not Applicable.

(4) Parts Disposition. Parts removed and not reinstalled are considered excess for kit application. Excess parts may be reused on another depot overhaul program or otherwise disposed of in accordance with AR 725-50 or local salvage regulations. T130 E1 track removed from vehicle will be inspected and classified IAW TM 9-2530-200-24 dated, March 2006. Refer to Table 1, listed in WP 0002 00.

- h. Special Tools; Tool Kits; Jigs; Test, Measurement and Diagnostic Equipment (TMDE), and Fixtures Required. Common hand tools (wrenches, sockets, screwdrivers); metal cutting tools (drill bits, taps, saws); and other tools (drills, grinders, shop equipment) are furnished by the maintenance shop/contractor.

REQUIRED COMMON TOOLS FOR INSTALLATION

NSN	NOMENCLATURE	CAGEC	PART NO.	QUANTITY
5120-01-240-6040	Crowbar	19207	11655778-5	1
4910-00-253-2478	Grease Gun	19207	10915142	1
5120-00-061-8546	Hammer 2 lb	19207	11677028-3	1
		OR		
5120-01-399-9254	Hammer 4 lb	1CV05	1435G	1
5120-00-264-3796	Adjustable Wrench	19207	11655778-5	1
5120-00-041-4624	Track Fixture	19207	12253183	2
4240-00-052-3776	Industrial Goggles	19207	-	1
5180-00-177-7033	Gen. Mechanics Tool Kit	19207	-	1

- i. Modification Procedures. Refer to Modifications Procedures/Sequencing Work package for compliance.
- j. Calibration Requirements. No calibration is required of the modified vehicle.
- k. Weight and Balance Data. Weight and balance are not significantly affected.
- l. Quality Assurance Requirements.
- (1) Perform Quality Assurance inspections to verify requirements of paragraph i, which define the minimum inspections to be performed. Documented Quality evidence of inspections performed and compliance with requirements will be accomplished as specified by the maintenance Quality activity.
- (2) Inspection.
- (a) In-process Inspection. Perform monitoring-type inspection of processes to assure compliance with requirements. The following items can only be monitored prior to completion of other steps.
- 1 Ensure track assemblies for T150F track have correct number of track shoes (63 left side, 64 right side M113A2 FOV, M113A3 FOV and OSV; 66 left and right side M548A1/A3).
- 2 Ensure rework of components is accomplished in their workstations IAW requirements of TB.
- m. Recording and Reporting of the Modification. Refer to DA Pamphlet 738-750.
- (1) Marking Equipment. Not applicable.
- n. Material Change (MC) Number. Not applicable.
- o. Modification Identification. Not applicable.

END OF WORK PACKAGE

MODIFICATION PROCEDURES/SEQUENCING**0002 00****THIS WORK PACKAGE COVERS:**

General (page 0002 00-1), Disassembly (page 0002 00-2), Assembly (page 0002 00-5), Final Inspection (page 0002 00-12).

References (continued)**INITIAL SETUP:****Maintenance Level**

Unit

TM 9-2350-247-10

TM 9-2350-247-20

TM 9-2350-366-10-1

TM 9-2350-366-20-1

Tools and Special Tools

Modification Kit 57K4269 (WP 0001 00)

Personnel Required

Tracked Vehicle mechanic (63Y-63T MOS) or heavy mobile equipment mechanic and two helpers

Materials/Parts

Modification Kit 57K4269 (WP 0001 00)

Estimated Time To Complete the Task

4 man-hours

References

TM 9-2350-277-10

TM 9-2350-277-20

TM 9-2350-261-10

TM 9-2350-261-20

Equipment Conditions

Vehicle on level surface

Engine stopped (see your -10)

Vehicle blocked (see your -10)

GENERAL**Scope.**

This work package provides shop instructions for the installation of T150F Track Assembly for carriers listed in Table 1 (WP 0001 00). If working on a M981 or M901A1 you will need to add four screws - B1821BH050C350N per vehicle to mount the track stowage brackets. The OSV does not have a stowage bracket for the spare track shoes at this time.

Facilities.

No special facilities are required other than that required for Unit/Direct/General Support maintenance. (See TM 9-2350-277-10 and -20 for M113A3 FOV; TM 9-2350-261-10 and -20 for M113A2 FOV; TM 9-2350-247-10 and -20 for M548A1/A3; or TM 9-2350-366-10-1 and -20-1 for OSV/MBT).

Tools and Equipment.

- a. Commonly used tools and equipment having application to unit maintenance, in general, will be furnished by the maintenance activity/contractor.
- b. Special tools and equipment having application to maintain M113A3 FOV carriers are listed in TM 9-2350-277-20 and TM 9-2350-277-24P, M113A2 FOV carriers are listed in TM 9-2350-261-20 and TM 9-2350-261-24P, M548A1/A3 carriers are listed in TM 9-2350-247-20 and TM 9-2350-247-24P, or OSV/MBT vehicles are listed in TM 9-2350-366-20-1 and TM 9-2350-366-24P-1 will be furnished by the unit/direct/general support activity/contractor.

MODIFICATION PROCEDURES/SEQUENCING (continued)**0002 00****CAUTION**

If vehicle has older Sprocket Wheel PN 8763352 it is necessary to replace it with the current Sprocket Wheel PN 10942567 to convert to T150F track.

DISASSEMBLY**1. Removal of Components.**

- a. The following paragraphs provide disassembly procedures to the extent necessary for installing T150F Track Assembly. Detailed procedures not contained herein may be found in applicable technical manuals (TM 9-2350-277-10 or -20 for the M113A3 FOV; TM 9-2350-261-10 or -20 for the M113A2 FOV; TM 9-2350-247-10 or -20 for the M548A1/A3; or TM 9-2350-366-10-1 or -20-1 for the OSV).
- b. Parts to be retained for rework or reuse during assembly, and parts considered excess during disassembly of the M113A3 FOV carriers, are identified by name and part number in the disassembly procedures. Dispose of excess parts IAW instructions from AR 725-50.
- c. Table 1 indicates parts that will be removed and reused, discarded, or considered excess, during disassembly/removal of T130E1 Track Assembly. The information to remove these items will be immediately following the table. The parts listed for reuse will be installed during assembly.
- d. Perform all disassembly and re-assembly steps for one track assembly. Then repeat all steps for the opposite side track assembly.
- e. The following reference tasks are equipment conditions required for disassembly (any unique tasks will be stated in the specific procedure):
 - (1) Vehicle on level surface.
 - (2) Engine stopped (see your -10).
 - (3) Vehicle blocked (see your -10)

**Table 1. PARTS REMOVED AND REUSED, DISCARDED, OR EXCESS
(QUANTITIES LISTED ARE FOR THE LEFT AND RIGHT SIDES)**

	NSN	NOMENCLATURE	CAGEC	PART NO.	QUANTITY
**	2520-00-678-8382	Wheel, Sprocket	19207	10942567	2
***	2350-00-078-2908	Track Assembly T130E1	19207	11677988	127or 166
***	3020-00-141-1154	Sprocket, Wheel	19207	11678255	4
***	2520-00-679-9657	Cushion, Rubber	19207	8763180	4
***	5306-01-131-9825	Bolt, Self-locking	19207	MS35764-1435	40
***	5306-01-132-3363	Bolt, Self-locking	19207	MS35764-1545	20

SPARE TRACK SHOES FOR MODIFICATION OF T130E1 TRACK ASSEMBLY TO T150F TRACK ASSEMBLY

***	2530-00-078-2908	Track Shoe Assembly	19207	11677988-6	2
***	5310-00-682-5992	Track Shoe Assembly	19207	8763458	4
***	5305-00-071-2069	Screw, Cap, Hexagon	19207	B1821BH050C150N	4

** Parts to be removed and reused

*** Parts to be removed and discarded

MODIFICATION PROCEDURES/SEQUENCING (continued)**0002 00****DISASSEMBLY - Continued****2. Storage Items.**

These items are to be removed and disposition of parts is as indicated on Table 1.

a. Remove Stowed Track Shoe Assemblies.

- (1) Remove four screws (B1821BH050C150N), flat washers (8763458), and two track shoe assemblies (11677988-6) stowed on the front of the vehicle.

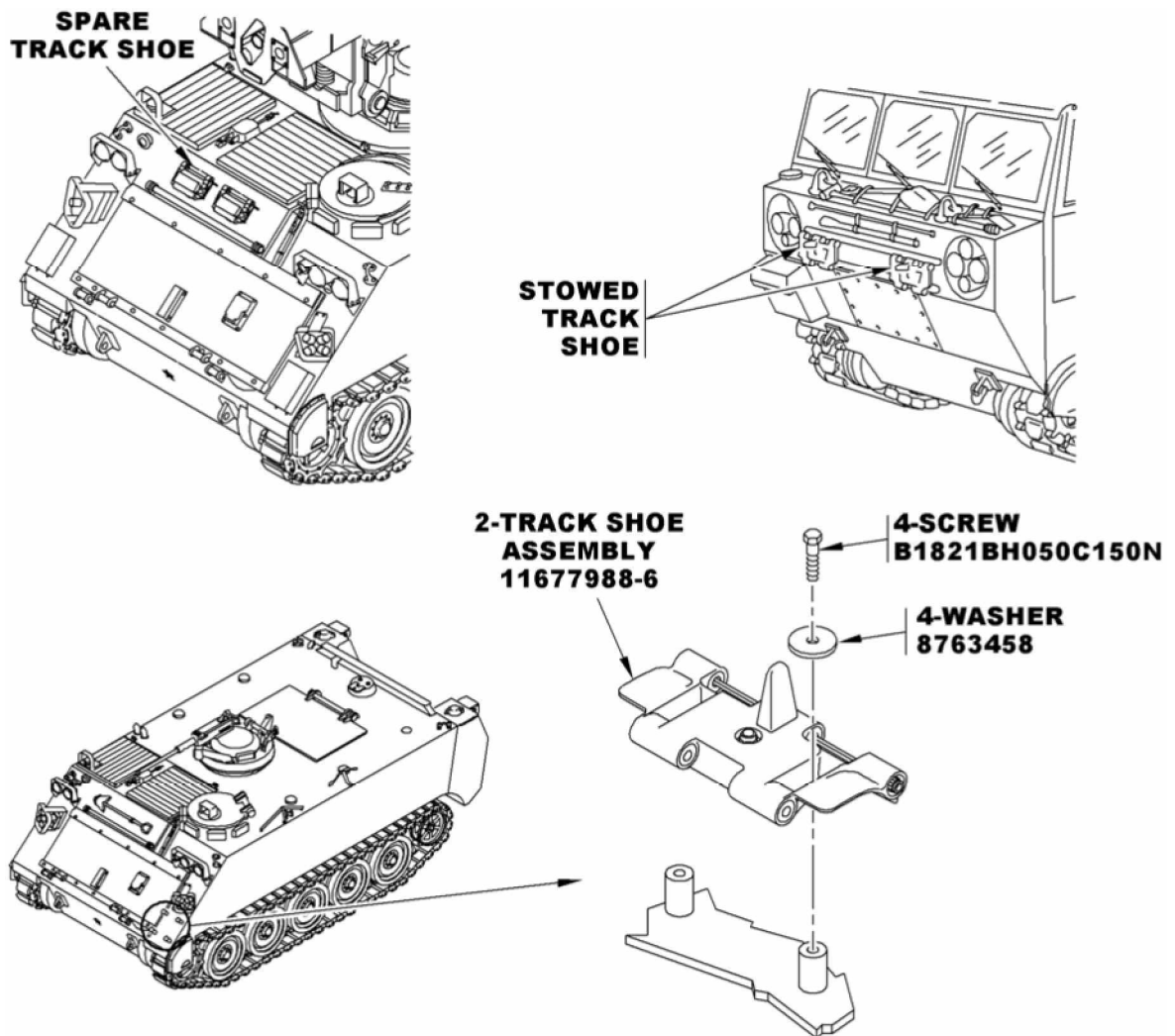

Figure 1. Remove Stowed Track Shoe Assemblies

DISASSEMBLY - Continued

- b. Remove two T130E1 Track Assemblies and Sprocket Wheel Assemblies from vehicle.

NOTE

Procedures are for one side and should be repeated for opposite side.

- (1) Remove T130E1 track assembly from vehicle (see your -10). Track assembly is to be discarded. IAW TM 9-2530-200-24, dated March 2006.
- (2) Remove ten self-locking bolts (MS35764-1545) and two sprocket wheel assemblies from final drive assembly.
- (3) Remove 20 self-locking bolts (MS35764-1435), two sprockets (11678255), and two cushions

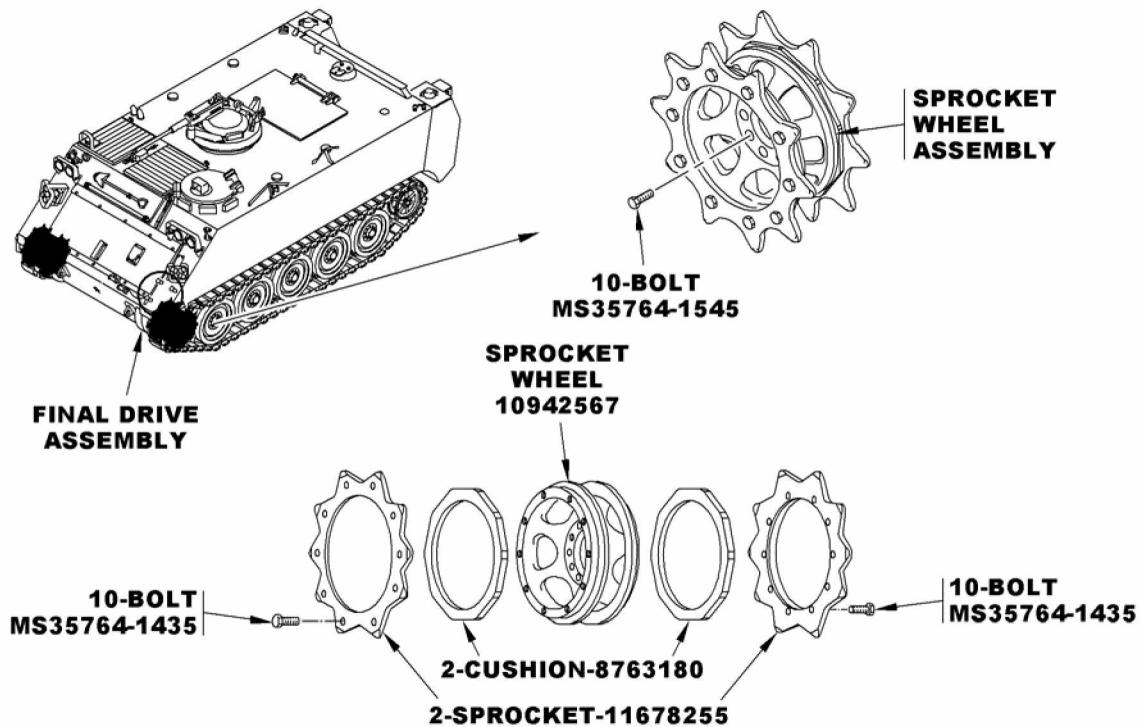

Figure 2. Remove One T130E1 Track Assembly and Sprocket Wheel Assembly from Vehicle

MODIFICATION PROCEDURES/SEQUENCING (continued)**0002 00****ASSEMBLY****1. Installation of Components.**

- a. General. Order of assembly of the vehicle will take place in the sequence shown in this TB. This will cover the components for installation of T150F Track Assembly.
- b. Procedures. The following pages will cover the procedures for describing the installation of components for installation of T150F Track Assembly.
- c. Follow-through steps to complete the TB maintenance will be described in Follow - Through Steps.

Table 2. TRACK ASSEMBLY INSTALLATION COMPONENTS

NSN	NOMENCLATURE	CAGEC	PART NO.	QUANTITY
2520-00-678-8382	Wheel, Sprocket	19207	10942567	2
3020-01-496-4445	Sprocket, Wheel	19207	12474840	4
5340-01-496-7433	Ring, Sprocket	19207	12474843	4
2520-00-679-9657	Cushion, Rubber	19207	8763180	4
5305-01-496-6745	Bolt, Self-locking	19207	MS35764-1445	40
5306-01-132-3363	Bolt, Self-locking	19207	MS35764-1545	20
2530-01-496-4444	Track Assembly	19207	12474844	127or166

ASSEMBLY - Continued

NOTE

Procedures are for one side. Repeat these steps for the opposite side.

- d. Install T150F track assembly sprockets on vehicle.
 - (1) Place two new rubber cushions (8763180) on sprocket wheel (10942567). Center short flat areas between mounting holes in sprocket wheel rim. Press on rubber cushions until firmly seated against flange of carrier.
 - (2) Install two rings (12474843), sprockets (12474840), and 20 self-locking bolts (MS35764-1445) on sprocket wheel. TORQUE BOLTS TO 110-115 lb-ft. (149-156 N m). Use torque wrench.
 - (3) Place sprocket wheel assembly on final drive. Secure with 10 self-locking bolts (MS35764-1545). Have helper assist. TORQUE BOLTS TO 170-190 lb-ft (231-258 N m). Use torque wrench.

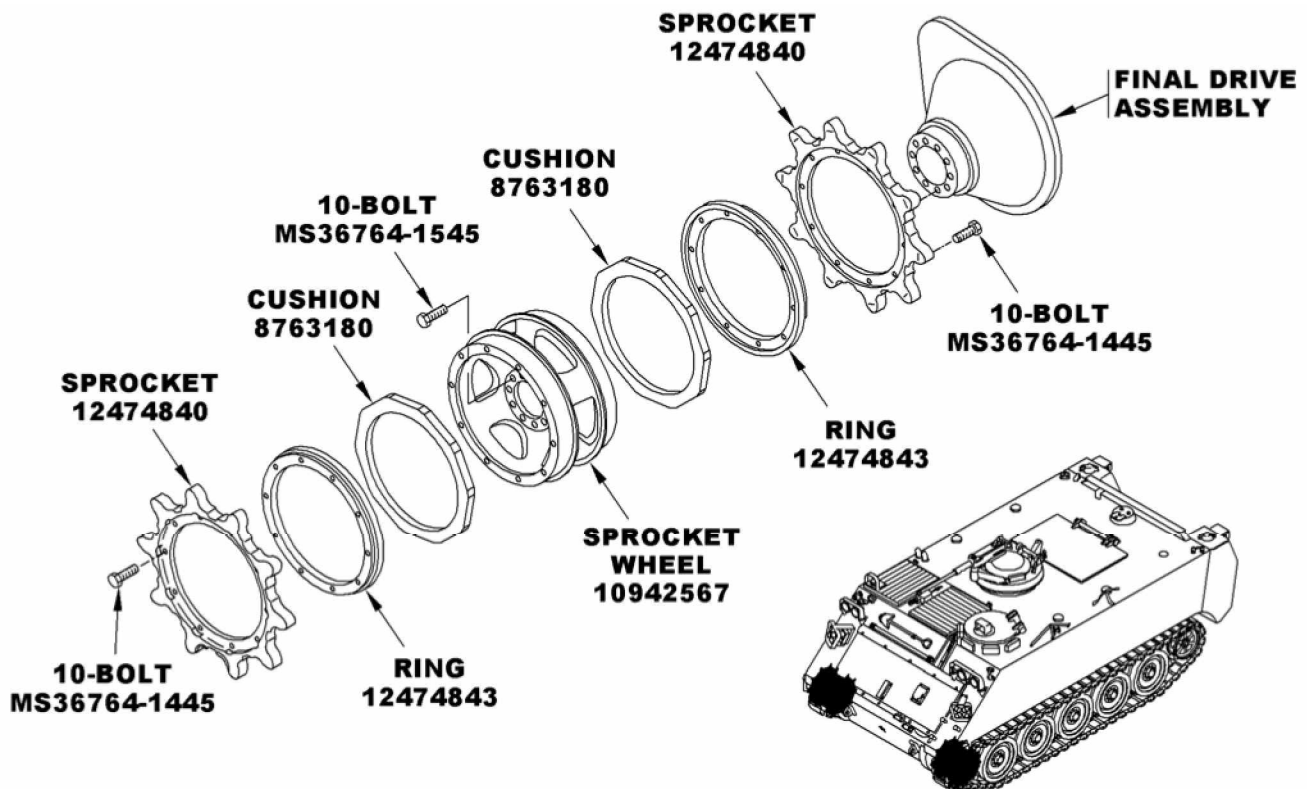

Figure 3. Install T150F Track Sprocket Wheel Assembly on Vehicle

MODIFICATION PROCEDURES/SEQUENCING (continued)**0002 00****ASSEMBLY - Continued**

- e. Install T150F Track Assembly on vehicle (Figure 4 through Figure 8).

WARNING

Improper number of track shoes may prevent track from being adjusted correctly, creating a safety hazard. Personnel may be killed and equipment damaged. For carriers with new track, ensure there are 63 track shoes on the left side of carrier and 64 track shoes on the right side of carrier for the M113A2 FOV, M113A3 FOV and OSV. For the M548A1/A3, 66 track shoes are required for both sides.

CAUTION

Be sure track shoe orientation matches that of the adjacent shoe. Center guides can not be next to each other.

NOTE

Track assembly can be installed from front to back or back to front. Going from the back to front can be easier with the sprocket wheel assembly to help push the track assembly over the top of the road wheels. Joining the track together will be between the sprocket wheel assembly and first road wheel or idler wheels and last road wheel.

If connecting the track at rear of vehicle (M113A2 FOV and M113A3 FOV only), have ramp closed and secured (see your -10) to allow access under the vehicle.

- (1) Position track assembly with proper number of shoes in a line in front or rear of vehicle. Align track guides of track assembly between first pair of road wheels. If track shoes came in sections of five or eight track shoes, connect 63 track shoes together for the left of the carrier (all except M548A1/M548A3) and 64 track shoes for the right side of the carrier (all except M548A1/M548A3). For the M548A1/M548A3, make sure you have 66 track shoes for both left and right.
- (2) Remove two end connectors from track shoes, to be joined together..

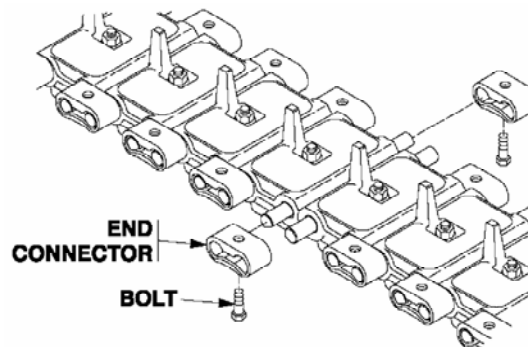
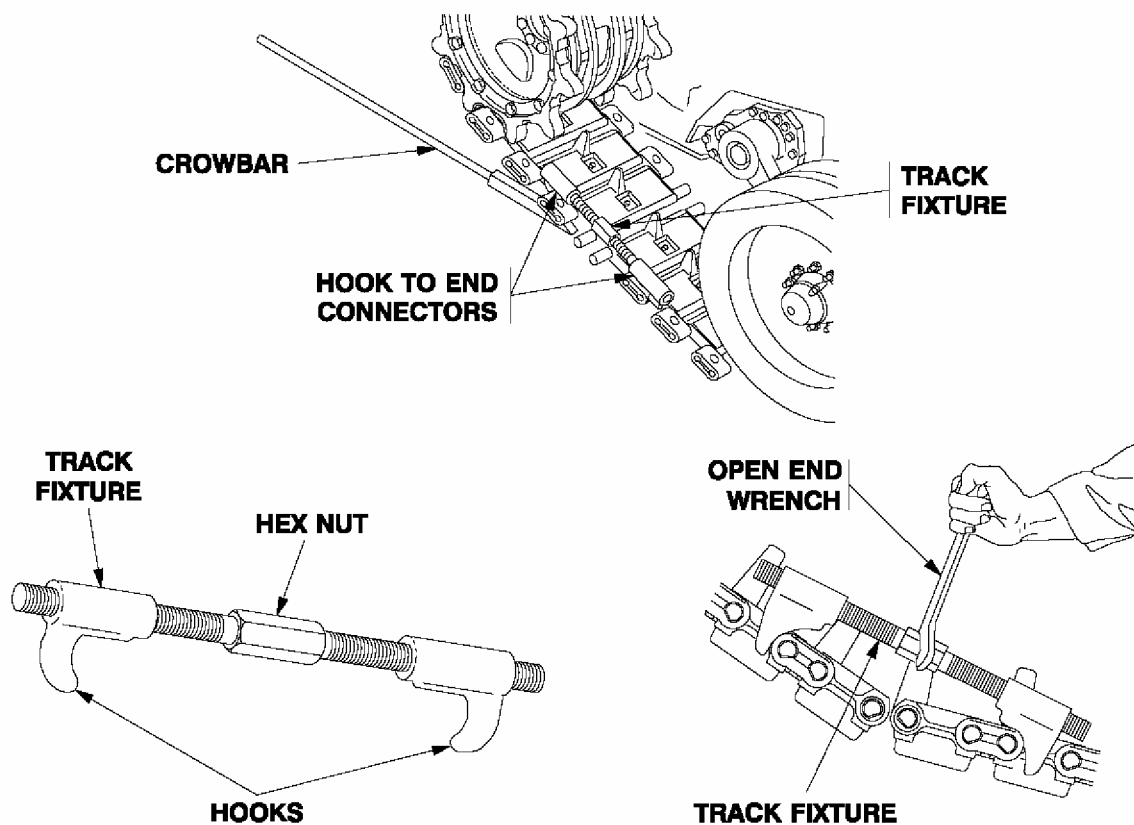

Figure 4. Install T150F Track Assembly on Vehicle

ASSEMBLY – Continued

- (3) Unblock vehicle (see your -10).
- (4) Have helper drive vehicle forward or reverse until track assembly positions on sprockets.
- (5) Have helper drive vehicle forward or reverse until track assembly is over idler wheels.
- (6) Hold track in position using crowbar. Hook track fixture to end connectors on either side of break. Install outside track fixture first, then install fixture to the inside of the track assembly.
- (7) Tighten two track fixtures evenly until ends of track are close enough to install end connectors.

**Figure 5. Install T150F Track Assembly on Vehicle**

MODIFICATION PROCEDURES/SEQUENCING (continued)**0002 00****ASSEMBLY - Continued**

- (8) Place alignment track pin tool (12474881) over one pin on the outside track shoe and rest it on the other pin. Tighten both track fixtures evenly to pull the track assembly together until the alignment track pin tool fits over and seats fully on both track shoe's pins. Install the second alignment track pin tool on the inside track shoe pins.
- (9) Remove the outside track fixture. Both alignment track pin tools will hold the track together. Leave the other track fixture on the inside of the track shoe.

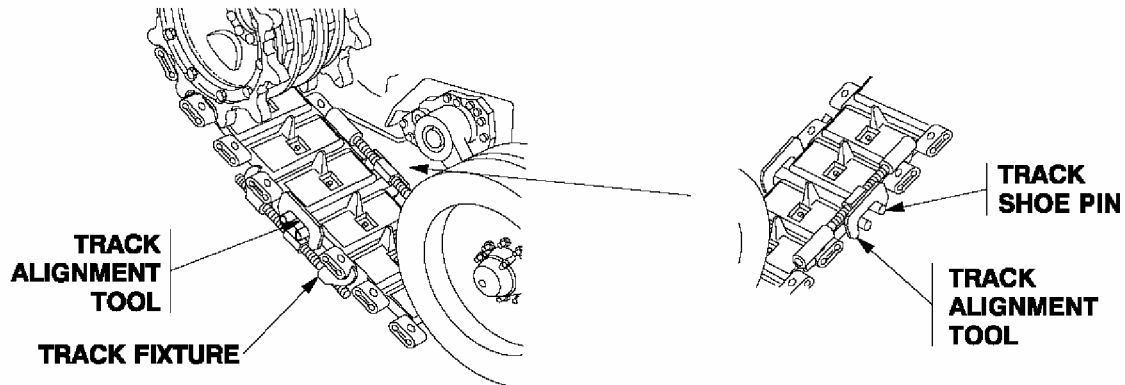
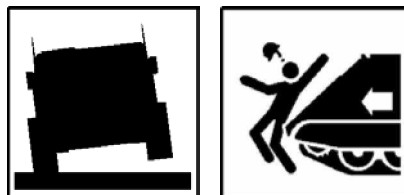

Figure 6. Install T150F Track Assembly on Vehicle

WARNING

Do not use a crowbar on the track shoe pins to get leverage. Any scratches may cause the pin to break and cause the track assembly to fall off the vehicle while operating. This may kill soldiers and damage equipment. Use crowbar as shown in the following steps to get leverage to install the end connectors.

NOTE

Place end connector or similar size block on top of the two track shoes being joined. Use the crowbar under the track fixture connected to the inside track shoes end connectors and press down on the block/end connector to get the right angle to install the end connector.

- (10) Make sure the inside track fixture is tight enough to allow the helper to use the crowbar under it with enough pressure to get the slight degree of angle between the two track shoes to allow installing the outside end connector. Use end connector or block to get the angle needed to install the end connector. Use end connector or block as leverage to get angle needed to install end connector.

ASSEMBLY - Continued

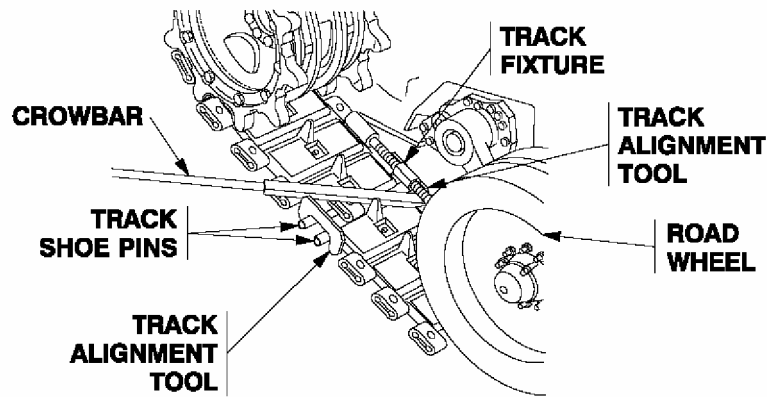
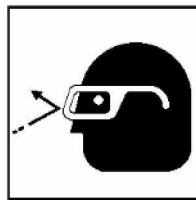

Figure 7. Install T150F Track Assembly on Vehicle

WARNING



Always wear eye protection when using a hammer. Eye injury may result if metal chips contact eyes.

- (11) Install the end connector on the outside track shoe pins. Get the angle needed to allow the end connector to fit on the track shoe pins. Using a hammer, tap on the end connector close to the alignment track pin tool. Remove the alignment track pin tool from the outside of the track shoe. Tap the end connector fully onto the track shoe's pins. Drive end connectors flush with pin ends, and install bolts on each end connector.

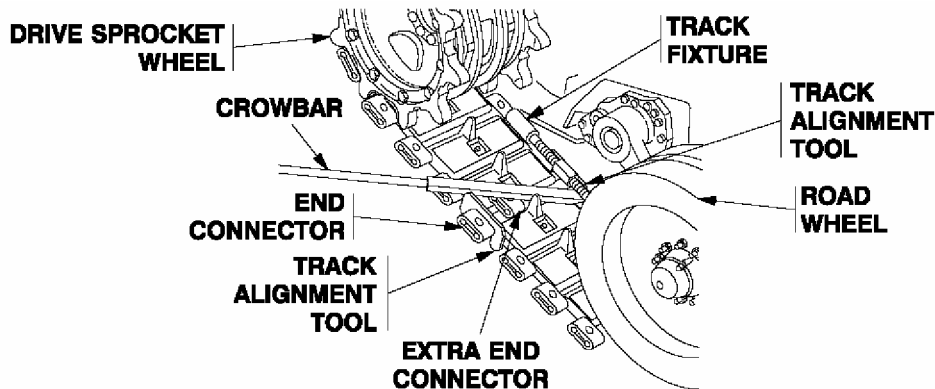
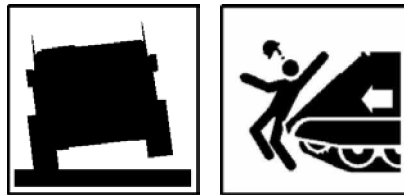

Figure 8. Install T150F Track Assembly on Vehicle

MODIFICATION PROCEDURES/SEQUENCING (continued)**0002 00****ASSEMBLY - Continued**

- (12) Install inside end connector. Only a slight amount or no leverage is needed to install the second end connector if the outside end connector is already installed.
- (13) With the end connector installed half way on the inside of the track shoe, remove the track fixture and alignment track pin tool. Finish installing the end connector flush with the pin ends.

WARNING

Not getting the bolt tight enough may result in death to personnel and damage to equipment if the end connectors fall off during movement of the vehicle. Torque each end connector bolt to the proper torque of 400-430 lb-ft(543-583 Nm).

NOTE

Mark the location of the end connectors so they can be torqued properly.

- (14) TORQUE END CONNECTORS' BOLTS TO 400-430 lb-ft (543-583 N m). Make sure to check every end connector bolt on the complete track assembly, even if it came in as a complete assembly.
- (15) Repeat installation procedures to the opposite side of the vehicle.
- (16) Adjust track tension (see your -10).
- f. Install T150F Spare Track Shoes and Brackets on vehicle (Figure 9).

**Table 3. SPARE TRACK SHOE INSTALLATION COMPONENTS
(OSV DOES NOT HAVE A STOWAGE LOCATION FOR THE SPARE TRACK SHOES)**

NSN	NOMENCLATURE	CAGEC	PART NO.	QUANTITY
5340-01-496-5173	Bracket, Track, Stowage	19207	12474841	2
2530-01-496-4444	Track Shoe Assembly	19207	12474844	127or166
5310-01-497-2285	Washer, Flat, Square	19207	12474863	4
5305-00-071-2067	Screw, Cap, Hex	80204	B1821BH050C125N	4
5305-00-071-2069	Screw, Cap, Hex	80204	B1821BH050C150N	4
5310-00-809-5998	Washer, Flat	96906	MS27183-18	8

Not included in the kit (replaces B1821BH050C150N). For M981/M901A1

5305-00-071-2077	Screw, Cap, Hex	80204	B1821BH050C350N	4
------------------	-----------------	-------	-----------------	---

ASSEMBLY - Continued

- (1) Place two track stowage brackets (12474841) on vehicle. Secure with four flat washers (MS27183-18) and screws (B1821BH050C150N) all except the M981 and M901A1. For the M981 and M901A1, use four screws (B1821BH050C350N).
- (2) Install two track shoes (12474844-1) on two brackets and secure with four square flat washers (12474863), flat washers (MS27183-18), and screws (B1821BH050C125N).

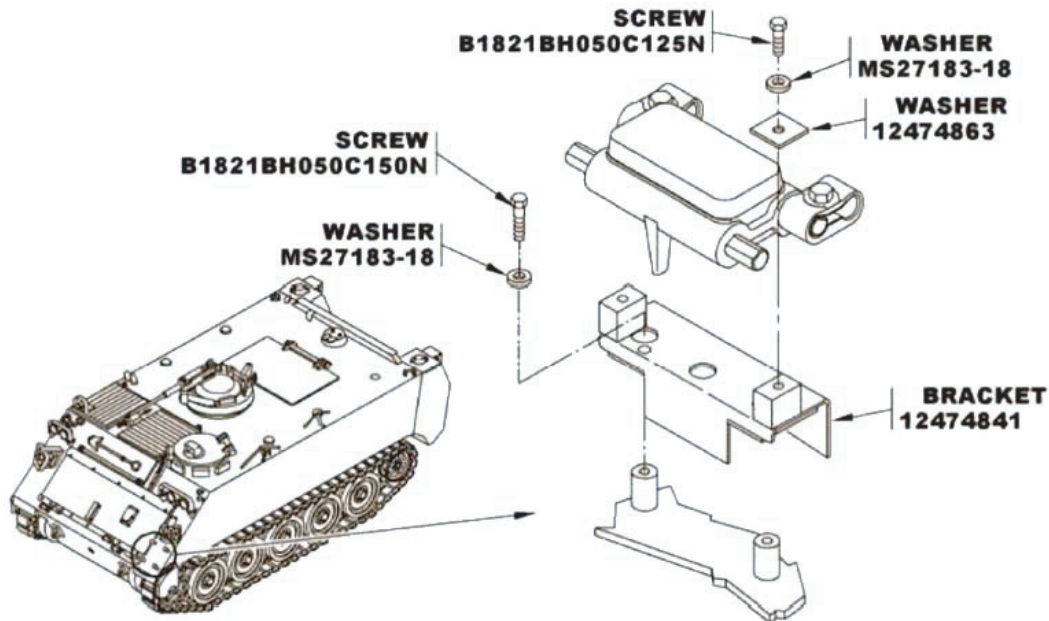
**FINAL INSPECTION****Final Inspection for T150F Track.**

1. Adjust track tension (see your -10).
2. Verify ALL end connector bolts have been secured and torqued to 400-430 lb-ft (543-583 N m).
3. If final inspection is complete and correct, perform FOLLOW-THROUGH STEPS.

FOLLOW-THROUGH STEPS

1. Unblock vehicle (see your -10).
2. Road test vehicle to check that track is installed correctly (see your -20).

MODIFICATION PROCEDURES/SEQUENCING (continued)

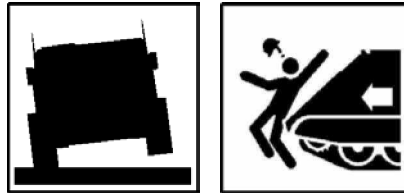
0002 00**ASSEMBLY - Continued****WARNING**

Not getting the bolt tight enough may result in death to personnel and damage to equipment if the end connectors fall off during movement of the vehicle. Torque each end connector bolt to the proper torque of 400-430 lb-ft(543-583 Nm).

3. CRITICAL SAFETY ITEM CHECK: After 30 to 60 miles of operation with new track, check torque on all end connector bolts. TORQUE TO 400-430 lb-ft (543-583 N m).
4. CRITICAL SAFETY ITEM CHECK: After 1500 miles of operation with new track reverse track (see your - 20). This extends the life of the track. Keep a record of when track is installed/reversed.

END OF WORK PACKAGE

REFERENCES**0003 00****SCOPE**

This work package lists technical manual and miscellaneous publications referenced in this bulletin.

TECHNICAL MANUALS

- Operator's Manual for Carrier, Personnel, Full Tracked, Armored M113A3 2350-01-219-7577 (EIC AEY), Carrier, Command Post, Light Tracked M577A3 2350-01-369-6085 (EIC AE7), Carrier, Smoke Generator, Full Tracked M1059A3 2350-01-369-6083 (EIC AFA), Carrier, Mortar, 120-Mm M121, Self-Propelled M1064A3 2350-01-369-6082 (EIC AE8), Carrier, Standardized Integrated Command Post System (SICPS) M1068A3 2350-01-369-6086 (EIC AFC), Carrier, Mechanized Smoke Obscurant M58 2350-01-418-6654 (EIC 5CG) TM 9-2350-277-10
- Unit Maintenance Manual for Carrier, Personnel, Full Tracked, Armored M113A3 2350-01-219-7577 (EIC AEY), Carrier, Command Post, Light Tracked M577A3 2350-01-369-6085 (EIC AE7), Carrier, Smoke Generator, Full Tracked M1059A3 2350-01-369-6083 (EIC AFA), Carrier, Mortar, 120-Mm M121, Self-Propelled M1064A3 2350-01-369-6082 (EIC AE8), Carrier, Standardized Integrated Command Post System (SICPS) M1068A3 2350-01-369-6086 (EIC AFC), Carrier, Mechanized Smoke Obscurant M58 2350-01-418-6654 (EIC 5CG) TM 9-2350-277-20
- Operators Manual For Carrier, Personnel, Full-Tracked, Armored 2350-01-068-4077, Carrier, Command Post, Light, Tracked, 2350-01-068-4089, Carrier, Mortar, 107-MM, M30, Self-Propelled M106A2 2350-01-069-693 Carrier, Mortar, 81-Mm, M29A1, Self Propelled M125A2 2350-01-068-4087 Carrier, Smoke Generator, Full Tracked 2350-01-203-0188 Carrier, Mortar, 120-Mm Self-Propelled, M106 2350-01-338-3116 Carrier, Standardized Integrated Command Post M1068 2351-01-354-5657 TM 9-2350-261-10
- Unit Maintenance Manual For Carrier, Personnel, Full Tracked: Armored, M113A2 2350-01-068-4077, Carrier, Command Post, Light Tracked, M577A2 2350-01-068-4089, Carrier, Mortar, 107-MM, M30; Self-Propelled, M106A2 2350-01-069-6931 Carrier, Mortar, 81-MM, M29A1; Self-Propelled, M125A2 2350-01-068-4087 Carrier, Mortar, 120-MM, M121, Self-Propelled, M1064 2350-01-338-3116 Chassis, Gun, Anti-Aircraft Artillery, 2350-01-099-8929, Carrier, Smoke Generator, Full Tracked, M105 2350-01-203-0188 Combat Vehicle, Anti-Tank, Improved Tow Vehicle, M901A1, 2350-01-103-5641 TM 9-2350-261-20
- Operators Manual For Carrier, Cargo, Tracked, 6-Ton, M548A1 2350-01-096-9356, M548A3 2350-01-369-6081, Carrier, Electronic Warfare Systems, Tracked, 6-Ton, M1015A1 2350-01-136-8745 TM 9-2350-247-10
- Unit Maintenance For Carrier, Cargo, Tracked, 6-Ton M548A1 2350-00-096-9356, M548A3 2350-01-369-6081, Carrier, Electronic Warfare Systems, Tracked, 6-Ton M1015A1 2350-01-136-8745 TM 9-2350-247-20
- Operator's Manual for Opposing Forces Surrogate Training Systems, Opposing Forces, Surrogate Vehicle (OSV) M113A3/BMP-2 (2350-01-420-4716); Main Battle Tank (MBT), M113A3/MBT (2350-01-513-4793) Hull TM 9-2350-366-10-1

REFERENCES

0003 00

Unit Maintenance Manual for Opposing Forces Surrogate Training Systems, Opposing Forces, Surrogate Vehicle (OSV) M113A3/BMP-2 (2350-01-420-4716); Main Battle Tank (MBT), M113A3/MBT (2350-01-513-4793) Hull

TM 9-2350-366-20-1

Other Publications.

First Aid

FM 4-25.11

Requisition, Receipt and Issue System

AR 725-50

The Army Maintenance Management Systems (TAMMS)

DA Pam 738-750

FORMS

Recommended Changes to Publications and Blank Forms

DA 2028

END OF WORK PACKAGE

INDEX

A - H

I

Introduction
General0001 00-1
Purpose.....0001 00-1

J - L

M

Modification Procedures/Sequencing
Assembly0002 00-5
Disassembly.....0002 00-2
Final Inspection.....0002 00-12
General0002 00-1

N - Q

R

References.....0003 00-1

S - Z

By Order of the Secretary of the Army:

Official:

A handwritten signature in black ink that reads "Joyce E. Morrow". The signature is written in a cursive style with a large initial "J" and "M".

JOYCE E. MORROW
*Administrative Assistant to the
Secretary of the Army*
0703002

PETER J. SCHOOMAKER
*General, United States Army
Chief of Staff*

Distribution:

To be distributed in accordance with the initial distribution number (IDN) 344871,
requirements for TB 9-2350-369-20-1

RECOMMENDED CHANGES TO PUBLICATIONS AND BLANK FORMS	Use Part II (reverse) for Repair Parts and Special Tools Lists (RPSTL) and Supply Catalogs/Supply Manuals SC/SM).	Date
For use of this form, see AR 25-30; the proponent agency is ODISC4.		

TO: (Forward to proponent of publication or form) (Include ZIP Code)	FROM: (Activity and location) (include ZIP code)
--	--

PART I - ALL PUBLICATIONS (EXCEPT RPSTL AND SC/SM) AND BLANK FORMS

PUBLICATION/FORM NUMBER TB 9-2350-369-20-1	DATE 28 February 2007	TITLE Modification to Convert M113A3 FOV Carriers, M113A2 FOV Carriers, M548A1/A3 Carriers And OSV/MBT Vehicles, T130E1 Track to T150F Track
---	--------------------------	---

ITEM	PAGE	PARA	LINE	FIGURE NO.	TABLE	RECOMMENDED CHANGES AND REASON
0052 00-4						Inspection Step 1 WP reference should be (WP 0003 00)

SAMPLE

*Reference to line numbers within the paragraph or subparagraph.		
TYPED, GRADE OR TITLE	TELEPHONE EXCHANGE/AUTOVON, PLUS EXTENSION	SIGNATURE

TO: (Forward direct to addressee listed in publication)	FROM: (Activity and location) (Include Zip Code)	Date
--	---	-------------

PART II - REPAIR PARTS AND SPECIAL TOOL LISTS AND SUPPLY CATALOGS/SUPPLY MANUALS

PUBLICATION/FORM NUMBER TB 9-2350-369-20-1	DATE 28 February 2007	TITLE Modification to Convert M113A3 FOV Carriers, M113A2 FOV Carriers, M548A1/A3 Carriers And OSV/MBT Vehicles, T130E1 Track to T150F Track
--	---------------------------------	--

PAGE NO.	COLM NO.	LINE NO.	NATIONAL STOCK NUMBER	REFERENCE NO.	FIGURE NO.	ITEM NO.	TOTAL NO. OF MAJOR ITEMS SUPPORTED	RECOMMENDED ACTION

SAMPLE

PART III - REMARKS *(Any general remarks or recommendations, or suggestions for improvement of publications and blank forms. Additional blank sheets may be used if more space is needed).*

TYPED, GRADE OR TITLE	TELEPHONE EXCHANGE/AUTOVON, PLUS EXTENSION	SIGNATURE
-----------------------	--	-----------

RECOMMENDED CHANGES TO PUBLICATIONS AND BLANK FORMS For use of this form, see AR 25-30; the proponent agency is ODISC4.	Use Part II (reverse) for Repair Parts and Special Tools Lists (RPSTL) and Supply Catalogs/Supply Manuals SC/SM).	Date
--	---	------

TO: (Forward to proponent of publication or form) (Include ZIP Code)	FROM: (Activity and location) (include ZIP code)
---	---

PART I - ALL PUBLICATIONS (EXCEPT RPSTL AND SC/SM) AND BLANK FORMS

PUBLICATION/FORM NUMBER TB 9-2350-369-20-1	DATE 28 February 2007	TITLE Modification to Convert M113A3 FOV Carriers, M1 13A2 FOV Carriers, M548A1/A3 Carriers And OSV/MBT Vehicles, T130E1 Track to T150F Track
---	------------------------------	--

ITEM	PAGE	PARA	LINE	FIGURE NO.	TABLE	RECOMMENDED CHANGES AND REASON

**Reference to line numbers within the paragraph or subparagraph.*

TYPED, GRADE OR TITLE	TELEPHONE EXCHANGE/AUTOVON, PLUS EXTENSION	SIGNATURE
-----------------------	---	-----------

TO: (Forward direct to addressee listed in publication)	FROM: (Activity and location) (Include Zip Code)	Date
--	---	-------------

PART II - REPAIR PARTS AND SPECIAL TOOL LISTS AND SUPPLY CATALOGS/SUPPLY MANUALS

PUBLICATION/FORM NUMBER TB 9-2350-369-20-1	DATE 28 February 2007	TITLE Modification to Convert M113A3 FOV Carriers, M113A2 FOV Carriers, M548A1/A3 Carriers And OSV/MBT Vehicles, T130E1 Track to T150F Track
---	--------------------------	---

PAGE NO.	COLM NO.	LINE NO.	NATIONAL STOCK NUMBER	REFERENCE NO.	FIGURE NO.	ITEM NO.	TOTAL NO. OF MAJOR ITEMS SUPPORTED	RECOMMENDED ACTION

PART III - REMARKS (Any general remarks or recommendations, or suggestions for improvement of publications and blank forms. Additional blank sheets may be used if more space is needed).

--

TYPED, GRADE OR TITLE	TELEPHONE EXCHANGE/AUTOVON, PLUS EXTENSION	SIGNATURE
-----------------------	--	-----------

RECOMMENDED CHANGES TO PUBLICATIONS AND BLANK FORMS					Use Part II (reverse) for Repair Parts and Special Tools Lists (RPSTL) and Supply Catalogs/Supply Manuals SC/SM).		Date
For use of this form, see AR 25-30; the proponent agency is ODISC4.							
TO: (Forward to proponent of publication or form) (Include ZIP Code)					FROM: (Activity and location) (include ZIP code)		
PART I - ALL PUBLICATIONS (EXCEPT RPSTL AND SC/SM) AND BLANK FORMS							
PUBLICATION/FORM NUMBER TB 9-2350-369-20-1					DATE 28 February 2007		TITLE Modification to Convert M113A3 FOV Carriers, M113A2 FOV Carriers, M548A1/A3 Carriers And OSV/MBT Vehicles, T130E1 Track to T150F Track
ITEM	PAGE	PARA	LINE	FIGURE NO.	TABLE	RECOMMENDED CHANGES AND REASON	
<i>*Reference to line numbers within the paragraph or subparagraph.</i>							
TYPED, GRADE OR TITLE					TELEPHONE EXCHANGE/AUTOVON, PLUS EXTENSION		SIGNATURE

DA FORM 2028, FEB 74 REPLACES DA FORM 2028, 1 DEC 68, WHICH WILL BE USED.
USAPPC V3.00

TO: (Forward direct to addressee listed in publication)	FROM: (Activity and location) (Include Zip Code)	Date
--	---	-------------

PART II - REPAIR PARTS AND SPECIAL TOOL LISTS AND SUPPLY CATALOGS/SUPPLY MANUALS

PUBLICATION/FORM NUMBER TB 9-2350-369-20-1	DATE 28 February 2007	TITLE Modification to Convert M113A3 FOV Carriers, M113A2 FOV Carriers, M548A1/A3 Carriers And OSV/MBT Vehicles, T130E1 Track to T150F Track
--	---------------------------------	--

PAGE NO.	COLM NO.	LINE NO.	NATIONAL STOCK NUMBER	REFERENCE NO.	FIGURE NO.	ITEM NO.	TOTAL NO. OF MAJOR ITEMS SUPPORTED	RECOMMENDED ACTION

PART III - REMARKS *(Any general remarks or recommendations, or suggestions for improvement of publications and blank forms. Additional blank sheets may be used if more space is needed).*

TYPED, GRADE OR TITLE	TELEPHONE EXCHANGE/AUTOVON, PLUS EXTENSION	SIGNATURE
-----------------------	--	-----------

THE METRIC SYSTEM AND EQUIVALENTS

LINEAR MEASURE

1 Centimeter = 10 Millimeters = 0.01 Meters = 0.3937 Inches
 Inches
 1 Meter = 100 Centimeters = 1000 Millimeters = 39.37 Inches
 Feet
 1 Kilometer = 1000 Meters = 0.621 Miles

WEIGHTS

1 Gram = 0.001 Kilograms = 1000 Milligrams = 0.035 Ounces
 Inches
 1 Kilogram = 1000 Grams = 2.2 Pounds
 Feet
 1 Metric Ton = 1000 Kilograms = 1 Megagram = 1.1 Short Tons

LIQUID MEASURE

1 Milliliter = 0.001 Liters = 0.0338 Fluid Ounces
 1 Liter = 1000 Milliliters = 33.82 Fluid Ounces

SQUARE MEASURE

1 Sq. Centimeter = 100 Sq. Millimeters = 0.155 Sq.

1 Sq. Meter = 10,000 Sq. Centimeters = 10.76 Sq.

1 Sq. Kilometer = 1,000 Sq. Meters = 0.386 Sq. Miles

CUBIC MEASURE

1 Cu. Centimeter = 1000 Cu. Millimeters = 0.06 Cu.

1 Cu. Meter = 1,000,000 Cu. Centimeters = 35.31 Cu.

TEMPERATURE

$5/9 (^{\circ}\text{F} - 32) = ^{\circ}\text{C}$

212° Fahrenheit is equivalent to 100° Celsius

90° Fahrenheit is equivalent to 32.2° Celsius

32° Fahrenheit is equivalent to 0° Celsius

$(9/5 \times ^{\circ}\text{C}) + 32 = ^{\circ}\text{F}$

TO CHANGE	TO	MULTIPLY BY
Inches	Centimeters	2.540
Feet	Meters	0.305
Yards	Meters	0.914
Miles	Kilometers	1.609
Square Inches	Square Centimeters	6.451
Square Feet	Square Meters	0.093
Square Yards	Square Meters	0.836
Square Miles	Square Kilometers	2.590
Acres	Square Hectometers	0.405
Cubic Feet	Cubic Meters	0.028
Cubic Yards	Cubic Meters	0.765
Fluid Ounces	Millimeters	29.573
Pints	Liters	0.473
Quarts	Liters	0.946
Gallons	Liters	3.785
Ounces	Grams	28.349
Pounds	Kilograms	0.454
Short Tons	Metric Tons	0.907
Pound-Feet	Newton-Meters	1.356
Pounds per Square Inch	Kilopascals	6.895
Miles per Gallon	Kilometers per Liter	0.425
Miles per Hour	Kilometers per Hour	1.609

TO CHANGE	TO	MULTIPLY BY
Centimeters	Inches	0.394
Meters	Feet	3.280
Meters	Yards	1.094
Kilometers	Miles	0.621
Square Centimeters	Square Inches	0.155
Square Meters	Square Feet	10.764
Square Meters	Square Yards	1.196
Square Kilometers	Square Miles	0.386
Square Hectometers	Acres	2.471
Cubic Meters	Cubic Feet	35.315
Cubic Meters	Cubic Yards	1.308
Milliliters	Fluid Ounces	0.034
Liters	Pints	2.113
Liters	Quarts	1.057
Liters	Gallons	0.264
Grams	Ounces	0.035
Kilograms	Pounds	2.205
Metric Tons	Short Tons	1.102
Newton-Meters	Pound-Feet	0.738
Kilopascals	Pounds per Square Inch	0.145
Kilometers per Liter	Miles per Gallon	2.354
Kilometers per Hour	Miles per Hour	0.621

